

# CILINDROS DE CARRERA CORTA SERIE "SSCY" Ø 12÷100 mm Y ACCESORIOS



1

Cilindros compactos adaptados para instalaciones en espacios reducidos:

- ejecución con o sin detección magnética
- simple efecto o doble vástago simple o pasante
- versiones antigiro y con fijaciones incorporadas
- posibilidad de elección entre juntas en NBR y POLIURETANO o Viton®
- ejecuciones especiales a petición



DATOS TÉCNICOS	POLIURETANO	NBR	Viton®	Baja Temperatura
Presión de trabajo	máx 10 bar (máx 1 MPa)			
Temperatura de trabajo	-10°C÷+80°C	-10°C÷+80°C	-10°C÷+150°C (Cil. non magnéticos)	-35°C÷+80°C
Fluido	Aire sin lubricación, si se utiliza aire lubricado, la lubricación debe ser continua			
Diámetros	Ø 12 ; Ø 16 ; Ø 20 ; Ø 25 ; Ø 32 ; Ø 40 ; Ø 50 ; Ø 63 ; Ø 80 ; Ø 100			
Tipo de construcción	A perfil			
Carrera standard	Doble efecto:	de Ø 12 a Ø 25 carrera de 5 a 50 mm de Ø 32 a Ø 40 carrera de 5 a 70 mm de Ø 50 a Ø 63 carrera de 5 a 110 mm de Ø 80 a Ø 100 carrera de 5 a 150 mm		
	Simple efecto:	de Ø 12 a Ø 25 carrera de 5 a 25 mm de Ø 32 a Ø 63 carrera de 5 a 50 mm		
	Antigiro:	de Ø 12 a Ø 63 carrera de 5 a 120 mm de Ø 80 a Ø 100 carrera de 5 a 150 mm		
	Vástago pasante hueco	de Ø 20 a Ø 40 carrera de 5 a 100 mm de Ø 50 a Ø 63 carrera de 5 a 130 mm de Ø 80 a Ø 100 carrera de 5 a 165 mm		
Versiones	Doble efecto, Simple efecto vástago extendido, simple efecto vástago retraído, Vástago pasante, Simple efecto vástago pasante, Vástago pasante perforado, Antirrotación, Antirrotación oscilante macho, Antirrotación oscilante hembra			
Imanes para sensores	Todas las versiones con detección magnética a petición sin detección			
Presión de arranque	de Ø 12 a Ø 32: 0.6 bar - de Ø 40 a Ø 100: 0.4 bar			
Fuerza a desarrollar a 6 bar en empuje/rotación	Ver DATOS TECNICOS GENERALES PAG. 1.1/05			
Pesos	Ver DATOS TECNICOS GENERALES PAG. 1.1/06			
	Para versiones anti stick slip utilizar sólo aire sin lubricación			

## COMPONENTES

- ① VASTAGO: acero C40 o inoxidable, cromado en profundidad
- ② CULATA: Ø 12÷25 latón OT 58 pintado  
Ø 32÷100 aluminio pintado
- ③ JUNTAS VASTAGO:  
Ø 12÷63 SFR (PARKER PRADIFA) NBR o Viton®  
Ø 80÷100 Poliuretano (PARKER PRADIFA) NBR o Viton®
- ④ CASQUILLO DE GUIA: fleje acero con recubrimiento de bronce y de PTFE
- ⑤ CAMISA: Aleación de aluminio perfilado y anodizado
- ⑥ PISTON:  
Ø 12÷63 resina acetálica  
Ø 80÷100 en aluminio con patín de guía en PTFE
- ⑦ JUNTAS PISTON:  
Ø 12÷63 Poliuretano (PARKER PRADIFA) NBR o Viton®  
Ø 80÷100 SFR (PARKER PRADIFA) NBR o Viton®
- ⑧ IMANES: Ø 12÷25 neodimio - Ø 63÷100 plastoferrita
- ⑨ OR estáticos: NBR o Viton®

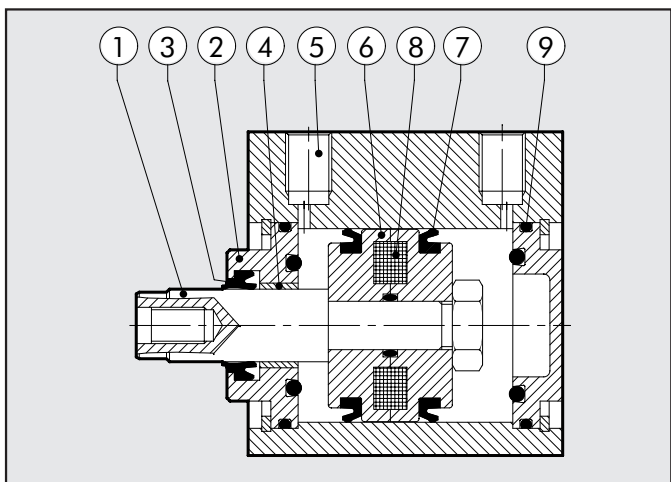

### POSIBILIDAD DE FIJACIÓN CILINDROS SSC

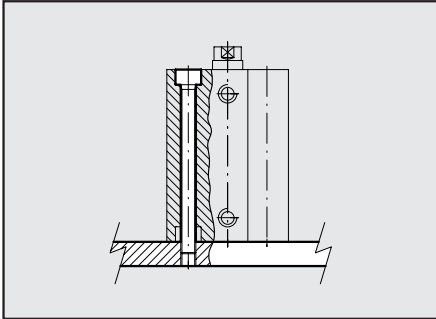

Fijación directa desde arriba con tornillos largos o con tirantes. En este caso se debe utilizar tornillos o tirantes en material de acero inoxidable (ej. AISI 304).

### DIMENSIONES VERSIONES STANDARD

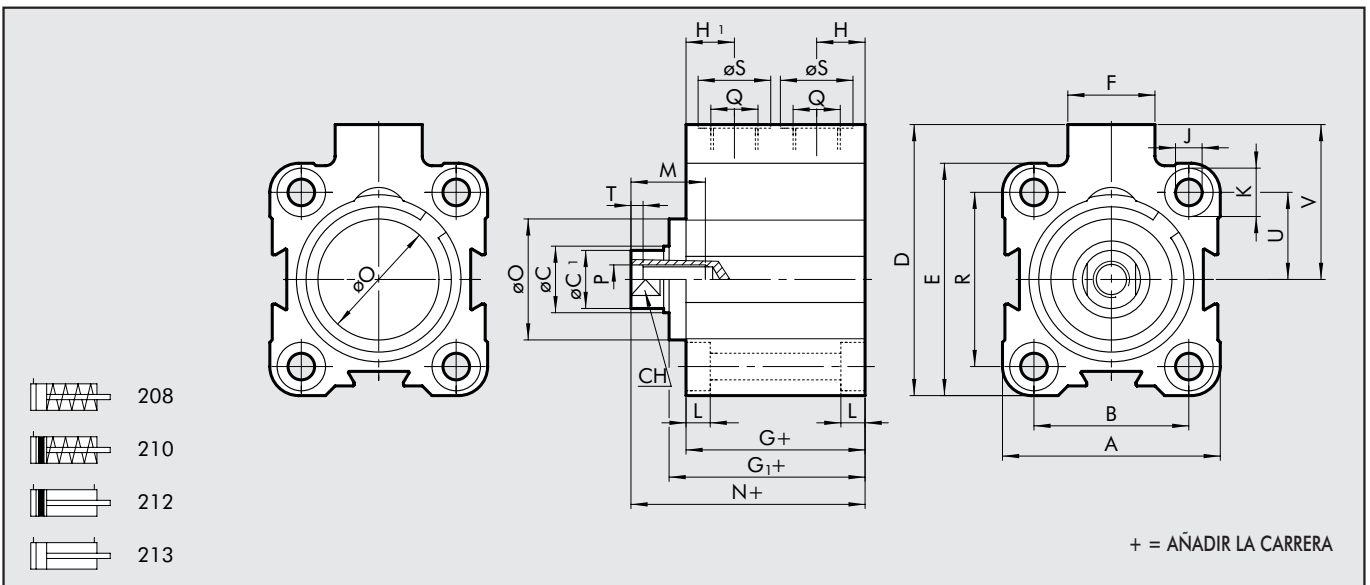

### DIMENSIONES DOBLE EFECTO STANDARD

Ø	A	B	øC	øC <sub>1</sub>	D	E	F	G	G <sub>1</sub>	H	H <sub>1</sub>	J	K	L	M	N	øO	P	Q	R	øS	CH	T	U	V
12	23.5	13	6	5.5	28	26	11	32.5		6.5	10.5	3.7	6	3.7	7	38		M3	M5		8	5	2	9.5	16.5
16	28	20	8	7.5	33	28	11	33		6.7	10.5	3.7	6	3.7	10	37.5		M5	M5	20	8	7	2	10	19
20	32	22	10	9	37	32	11	32		6.5	10.5	4.6	7.5	4.6	10	36.5		M5	M5	22	8	8	2	11	21
25	37	26	10	9	47.5	39	18	33	36.5	8.5	8.5	4.6	7.5	4.6	10	42.5	20	M5	G1/8	28	15	8	2	14	28
32	45	32	12	11	56	48	18	37	40.8	10	10	5.5	10	5.7	15	48.3	25	M6	G1/8	36	15	10	2.5	18	32
40	54.5	40	12	11	62.7	54.5	18	39.5	44.7	10	10	5.5	10	5.7	15	53.2	30	M6	G1/8	40	15	10	2.5	20	35.5
50	66	50	16	15	73	66	18	39.5	46.2	11	11	6.6	11	6.8	18	53.2	35	M8	G1/8	50	15	13	3.5	25	40
63	80	62	16	15	88	80	23	42	48.7	12	12	9	15	9	18	57.7	35	M8	G1/8	62	15	13	3.5	31	48
80	100	82	20	19	110	100	26	57	67.2	14	14	9	15	9	18	75.2	44	M10	G1/4	82	19	17	4	41	60
100	124	103	25	24	134	124	26	64	74.7	15	15	11	18	11	20	84.3	56	M12	G1/4	103	19	22	5	51.5	72

### DIMENSIONES SIMPLE EFECTO VÁSTAGO RETRAIDO

Ø	carrera	A	B	øC	øC <sub>1</sub>	D	E	F	G	G <sub>1</sub>	H	H <sub>1</sub>	J	K	L	M	N	øO	P	Q	R	øS	CH	T	U	V
12	5÷25	23.5	13	6	5.5	28	26	11	32.5		6.5	10.5	3.7	6	3.7	7	38		M3	M5		8	5	2	9.5	16.5
16	5÷25	28	20	8	7.5	33	28	11	33		6.7	10.5	3.7	6	3.7	10	37.5		M5	M5	20	8	7	2	10	19
20	5÷25	32	22	10	9	37	32	11	32		6.5	10.5	4.6	7.5	4.6	10	36.5		M5	M5	22	8	8	2	11	21
25	5÷25	37	26	10	9	47.5	39	18	33	36.5	8.5	8.5	4.6	7.5	4.6	10	42.5	20	M5	G1/8	28	15	8	2	14	28
32	5÷25	45	32	12	11	56	48	18	37	40.8	10	10	5.5	10	5.7	15	48.3	25	M6	G1/8	36	15	10	2.5	18	32
	>25÷50								45	48.8							56.3									
40	5÷25	54.5	40	12	11	62.7	54.5	18	39.5	44.7	10	10	5.5	10	5.7	15	53.2	30	M6	G1/8	40	15	10	2.5	20	35.5
	>25÷50								47.5	52.7							61.2									
50	5÷25	66	50	16	15	73	66	18	39.5	46.2	11	11	6.6	11	6.8	18	53.2	35	M8	G1/8	50	15	13	3.5	25	40
	>25÷50								47.5	54.2							61.2									
63	5÷25	80	62	16	15	88	80	23	42	48.7	12	12	9	15	9	18	57.7	35	M8	G1/8	62	15	13	3.5	31	48
	>25÷50								50	56.7							65.7									



**DIMENSIONES VERSIÓN VÁSTAGO EXTENDIDO**

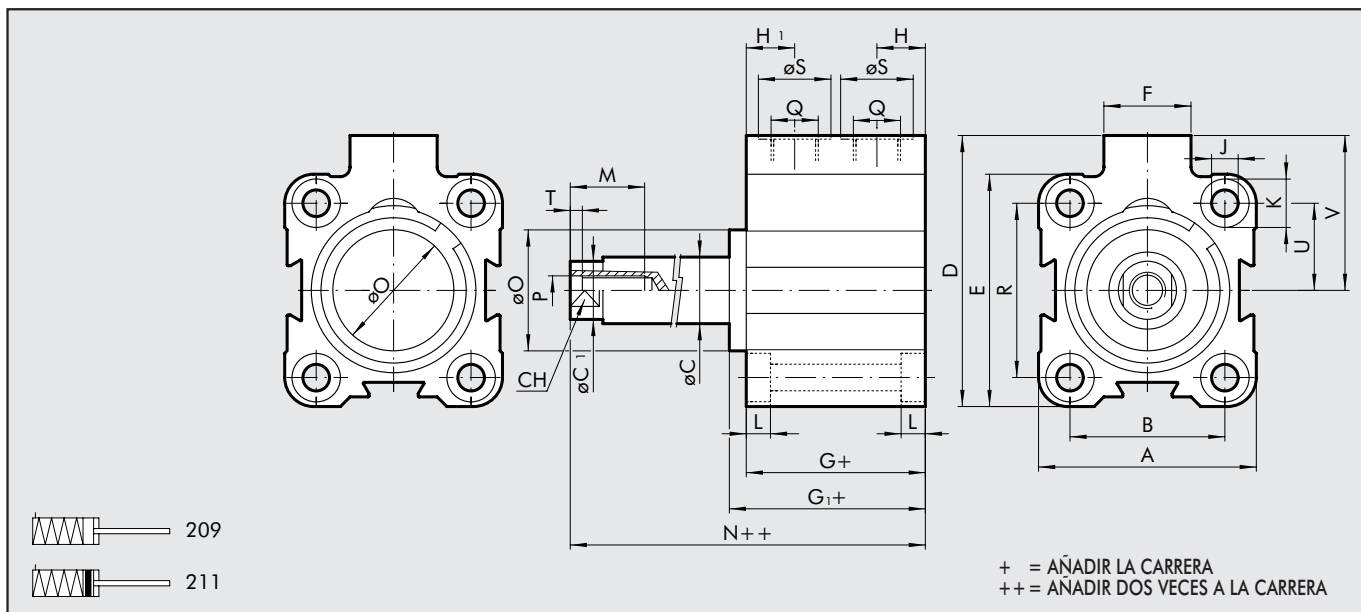

Ø	carrera	A	B	øC	øC <sub>1</sub>	D	E	F	G	G <sub>1</sub>	H	H <sub>1</sub>	J	K	L	M	N	øO	P	Q	R	øS	CH	T	U	V
12	5÷25	23.5	13	6	5.5	28	26	11	32.5		6.5	10.5	3.7	6	3.7	7	38		M3	M5	8	5	2	9.5	16.5	
16	5÷25	28	20	8	7.5	33	28	11	33		6.7	10.5	3.7	6	3.7	10	37.5		M5	M5	20	8	7	2	10	19
20	5÷25	32	22	10	9	37	32	11	32		6.5	10.5	4.6	7.5	4.6	10	36.5		M5	M5	22	8	8	2	11	21
25	5÷25	37	26	10	9	47.5	39	18	33	36.5	8.5	8.5	4.6	7.5	4.6	10	42.5	20	M5	G1/8	28	15	8	2	14	28
32	5÷25	45	32	12	11	56	48	18	37	40.8	10	10	5.5	10	5.7	15	48.3	25	M6	G1/8	36	15	10	2.5	18	32
	>25÷50								45	48.8							56.3									
40	5÷25	54.5	40	12	11	62.7	54.5	18	39.5	44.7	10	10	5.5	10	5.7	15	53.2	30	M6	G1/8	40	15	10	2.5	20	35.5
	>25÷50								47.5	52.7							61.2									
50	5÷25	66	50	16	15	73	66	18	39.5	46.2	11	11	6.6	11	6.8	18	53.2	35	M8	G1/8	50	15	13	3.5	25	40
	>25÷50								47.5	54.2							61.2									
63	5÷25	80	62	16	15	88	80	23	42	48.7	12	12	9	15	9	18	57.7	35	M8	G1/8	62	15	13	3.5	31	48
	>25÷50								50	56.7							65.7									

**DIMENSIONES Ø 12 VERSIONES ANTIGRO**

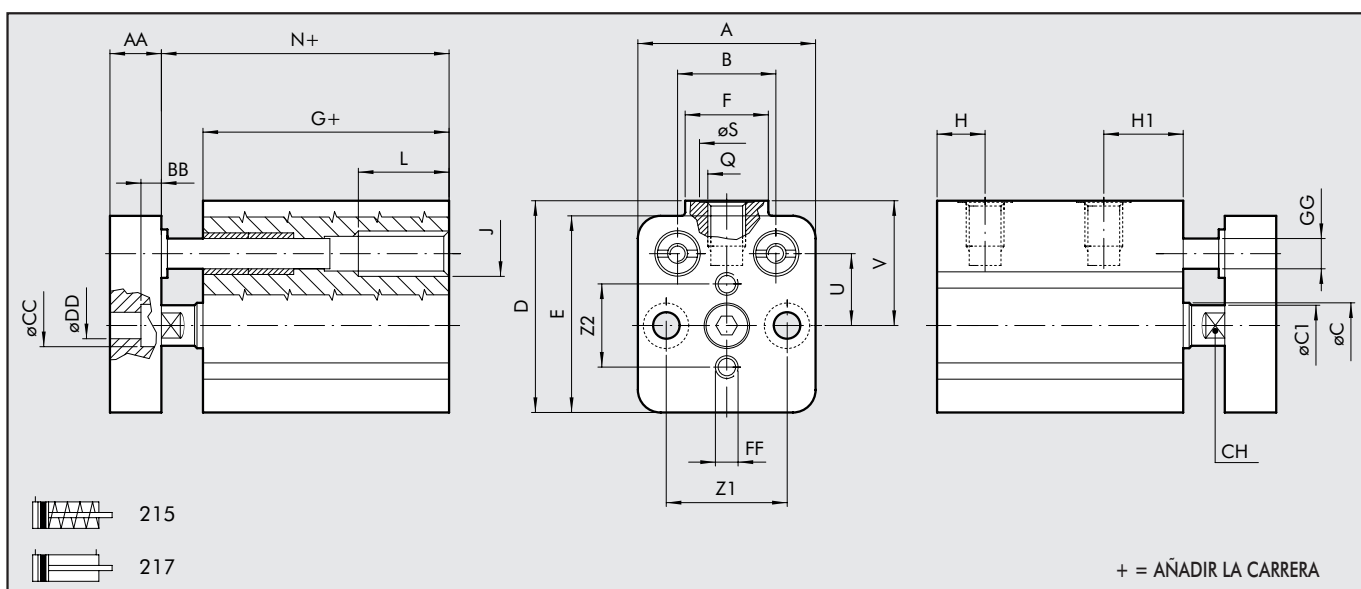

Ø	A	B	øC	øC <sub>1</sub>	D	E	F	G	H	H <sub>1</sub>	J	L	N	Z <sub>1</sub>	Z <sub>2</sub>	Q	øS	U	V	AA	BB	øCC	øDD	FF	øGG
12	23.5	13	6	5.5	28	26	11	32.5	6.5	10.5	M6	12	38	16	11	M5	8	9.5	16.5	8	3.5	6	3.5	M3	4

**DIMENSIONES Ø 16÷100 VERSIONES ANTIGIRO**

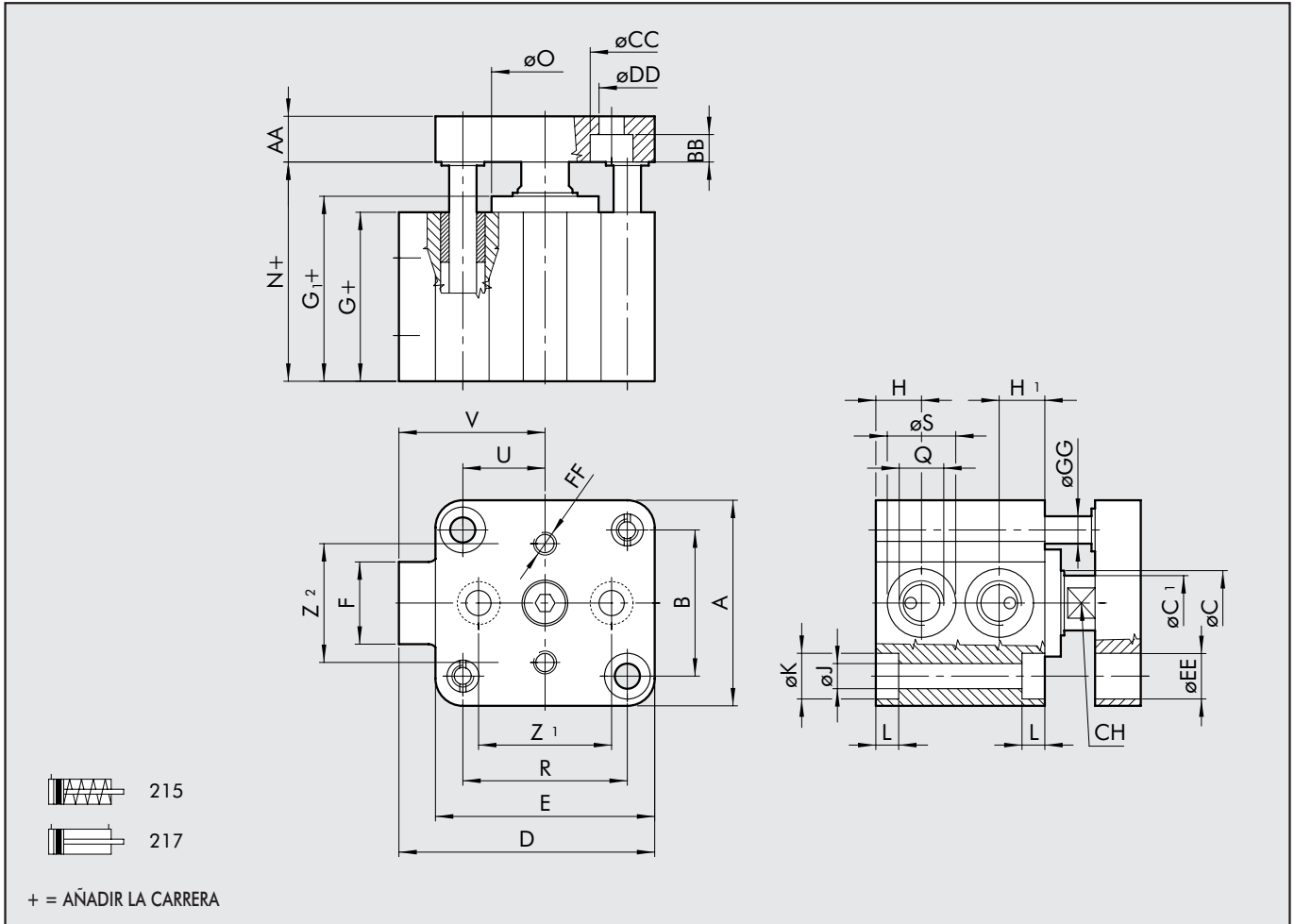

Ø	A	B	øC	øC <sub>1</sub>	D	E	F	G	G <sub>1</sub>	H	H <sub>1</sub>	J	K	L	N	Z <sub>1</sub>	Z <sub>2</sub>	Q	R	øS	CH	U
16	28	20	8	7.5	33	28	11	33		6.7	10.5	3.7	6	3.7	37.5	20	15	M5	20	8	7	10
20	32	22	10	9	37	32	11	32		6.5	10.5	4.6	7.5	4.6	36.5	22	18	M5	22	8	8	11
25	37	26	10	9	47.5	39	18	33	36.5	8.5	8.5	4.6	7.5	4.6	42.5	22	22	G1/8	28	15	8	14
32	45	32	12	11	56	48	18	37	40.8	10	10	5.5	10	5.7	48.3	26	26	G1/8	36	15	10	18
40	54.5	40	12	11	62.7	54.5	18	39.5	44.7	10	10	5.5	10	5.7	53.2	34	34	G1/8	40	15	10	20
50	66	50	16	15	73	66	18	39.5	46.2	11	11	6.6	11	6.8	53.2	43	43	G1/8	50	15	13	25
63	80	62	16	15	88	80	23	42	48.7	12	12	9	15	9	57.7	55	55	G1/8	62	15	13	31
80	100	82	20	19	110	100	26	57	67.2	14	14	9	15	9	75.2	70	70	G1/4	82	19	17	41
100	124	103	25	24	134	124	26	64	74.7	15	15	11	18	11	84.3	94	94	G1/4	103	19	22	51.5

Ø	V	AA	BB	øCC	øDD	øEE	FF	øGG	øO
16	19	8	3.5	6	3.5	6	M3	4	
20	21	8	5	7.5	4.5	7.5	M4	6	
25	28	8	5	7.5	4.5	8	M4	6	20
32	32	10	6	10	5.5	10	M5	8	25
40	35.5	10	6	10	5.5	10	M5	8	30
50	40	12	7	11	6.5	11	M6	10	35
63	48	12	9	14	9	15	M6	10	35
80	60	14	9	14	9	15	M8	12	44
100	72	17	9	14	9	18	M8	12	56



## DIMENSIONES VERSIÓN VÁSTAGO PASANTE

1

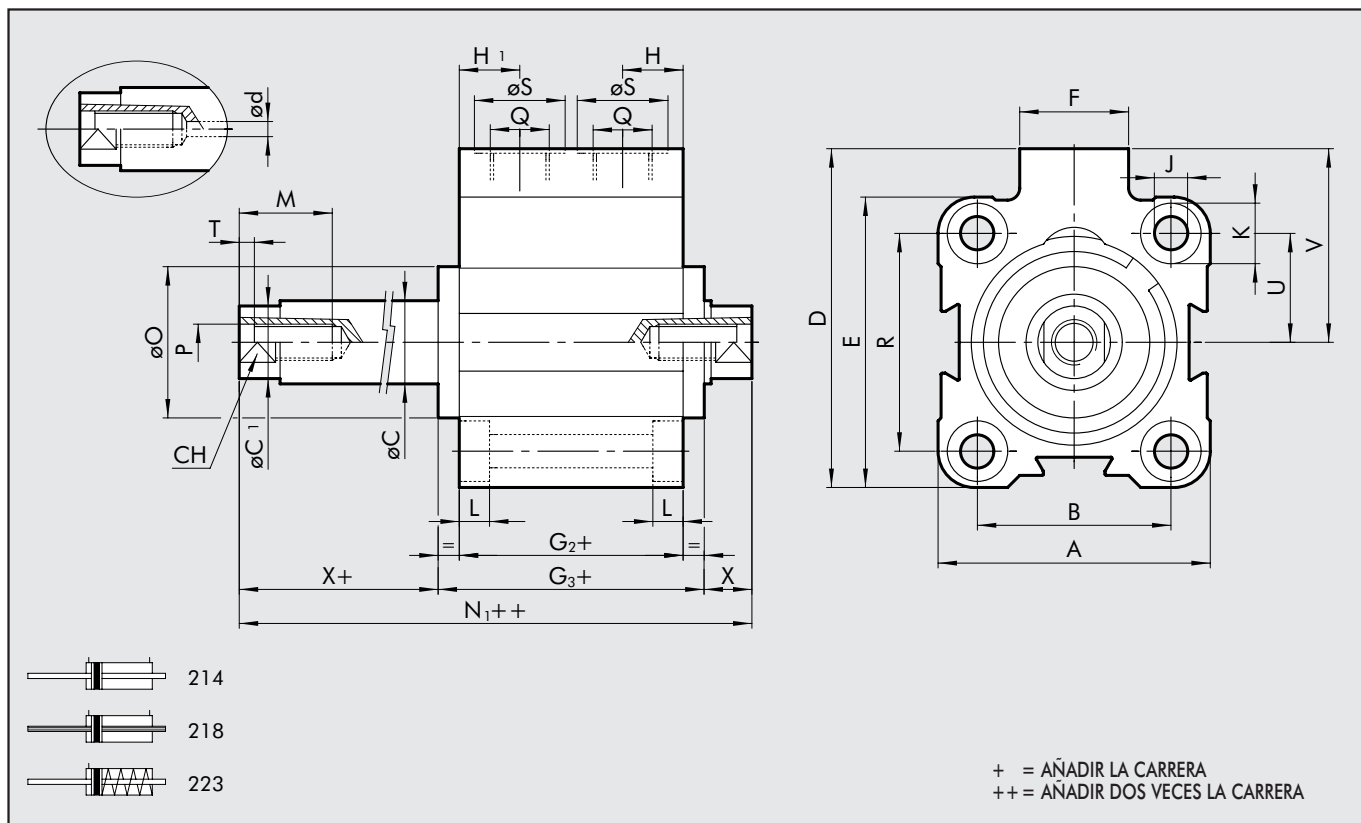

## DIMENSIONES DOBLE EFECTO VÁSTAGO PASANTE Y VÁSTAGO PASANTE PERFORADO

Ø	A	B	øC	øC <sub>1</sub>	D	ød**	E	F	G <sub>2</sub>	G <sub>3</sub>	H	H <sub>1</sub>	J	K	L	M	N <sub>1</sub>	øO	P	Q	R	øS	CH	T	U	V	X*
12	23.5	13	6	5.5	28		26	11	36.7		10.5	10.5	3.7	6	3.7	7	47.7		M3	M5		8	5	2	9.5	16.5	5.5
16	28	20	8	7.5	33		28	11	36.8		10.5	10.5	3.7	6	3.7	10	45.8		M5	M5	20	8	7	2	10	19	4.5
20	32	22	10	9	37	1.5	32	11	36		10.5	10.5	4.6	7.5	4.6	10	45.0		M5	M5	22	8	8	2	11	21	4.5
25	37	26	10	9	47.5	1.5	39	18	35.7	42.7	8.5	8.5	4.6	7.5	4.6	10	54.7	20	M5	G1/8	28	15	8	2	14	28	6
32	45	32	12	11	56	2.5	48	18	37	44.5	10	10	5.5	10	5.7	15	59.5	25	M6	G1/8	36	15	10	2.5	18	32	7.5
40	54.5	40	12	11	62.7	2.5	54.5	18	39.5	49.9	10	10	5.5	10	5.7	15	66.9	30	M6	G1/8	40	15	10	2.5	20	35.5	8.5
50	66	50	16	15	73	2.5	66	18	39.5	52.9	11	11	6.6	11	6.8	18	66.9	35	M8	G1/8	50	15	13	3.5	25	40	7
63	80	62	16	15	88	4	80	23	42	55.4	12	12	9	15	9	18	73.4	35	M8	G1/8	62	15	13	3.5	31	48	9
80	100	82	20	19	110	5	100	26	57	77.4	14	14	9	15	9	18	93.4	44	M10	G1/4	82	19	17	4	41	60	8
100	124	103	25	24	134	6	124	26	64	85.4	15	15	11	18	11	20	104.6	56	M12	G1/4	103	19	22	5	51.5	72	9.6

\*para Ø12, Ø16, Ø20: (N<sub>1</sub>++) = (G<sub>2</sub>+) + (X) + (X+)

\*\*Columna solamente para vástago pasante perforado

## DIMENSIONES SIMPLE EFECTO VÁSTAGO PASANTE

Ø	carrera	A	B	øC	øC <sub>1</sub>	D	E	F	G <sub>2</sub>	G <sub>3</sub>	H	H <sub>1</sub>	J	K	L	M	N <sub>1</sub>	øO	P	Q	R	øS	CH	T	U	V	X*
12	5÷25	23.5	13	6	5.5	28	26	11	36.7		10.5	10.5	3.7	6	3.7	7	47.7		M3	M5		8	5	2	9.5	16.5	5.5
16	5÷25	28	20	8	7.5	33	28	11	36.8		10.5	10.5	3.7	6	3.7	10	45.8		M5	M5	20	8	7	2	10	19	4.5
20	5÷25	32	22	10	9	37	32	11	36		10.5	10.5	4.6	7.5	4.6	10	45.0		M5	M5	22	8	8	2	11	21	4.5
25	5÷25	37	26	10	9	47.5	39	18	35.7	42.7	8.5	8.5	4.6	7.5	4.6	10	57.7	20	M5	G1/8	28	15	8	2	14	28	6
32	5÷25	45	32	12	11	56	48	18	37	44.5	10	10	5.5	10	5.7	15	59.5	25	M6	G1/8	36	15	10	2.5	18	32	7.5
	>25÷50								45	52.5							67.5										7.5
40	5÷25	54.5	40	12	11	62.7	54.5	18	39.5	49.9	10	10	5.5	10	5.7	15	66.9	30	M6	G1/8	40	15	10	2.5	20	35.5	8.5
	>25÷50								47.5	57.9							74.9										8.5
50	5÷25	66	50	16	15	73	66	18	39.5	52.9	11	11	6.6	11	6.8	18	66.9	35	M8	G1/8	50	15	13	3.5	25	40	7
	>25÷50								47.5	60.9							74.9										7
63	5÷25	80	62	16	15	88	80	23	42	55.4	12	12	9	15	9	18	73.4	35	M8	G1/8	62	15	13	3.5	31	48	9
	>25÷50								50	63.4							81.4										9

\*para Ø12, Ø16, Ø20: (N<sub>1</sub>++) = (G<sub>2</sub>+) + (X) + (X+)

### CLAVES DE CODIFICACIÓN

CIL	2	1	2	0	4	0	0	0	1	0	C	P	
	TIPOLOGIA			DIAMETRO		CARRERA							
■ 208	Simple efecto vástago retraído no magnético			0	Magnético	12	+	Ø 12÷25	A		Vástago cromado C45, pistón de aluminio	P	Juntas en poliuretano
■ 209	Simple efecto vástago extendido no magnético			S	No-magnético	16	+	Ø 32÷40	C		Ø 12÷63 mm C45 cromada, pistón tecnopolimero	N	Juntas en NBR
■ 210	Simple efecto vástago retraído			▲ G	Grasa no stick slip	20	+	Ø 50÷63	Z		Vástago y tuerca inox, pistón en aluminio	● V	Juntas en Viton®
■ 211	Simple efecto vástago extendido					25	+	Ø 80÷100	X		Vástago y tuerca inox, pistón en tecnopolimero	● B	baja temperatura
■ 212	Doble efecto magnético					32							
■ 213	Doble efecto no magnético					40							
■ 214	Doble efecto vástago pasante					50							
■ 215	Simple efecto retraído antigiro					63							
■ 217	Doble efecto antigiro					80							
▼ 218	Doble efecto vástago pasante perforado					100							
221	Charnela oscilante macho (sólo hasta Ø 63)												
222	Charnela oscilante hembra (sólo hasta Ø 63)												
■ 223	Simple efecto vástago pasante												

- ◆ Cuando la 4ª cifra está ocupada por una letra Ø 100 = A1
- Disponible para Ø63
- ▼ Disponible de Ø20
- Disponible sólo para versión no magnético (S) y con pistón en aluminio (A o Z)
- +

### DIMENSIONES VERSIÓN 222 (CHARNELA HEMBRA MOD. B)

Ø carrera D<sub>2</sub> G G<sub>1</sub> H<sub>6</sub> H<sub>8</sub> N R S<sub>1</sub> S<sub>2</sub>

32	5÷70	10	59	62.8	22	10	70.3	11	26	45
40	5÷70	12	64.5	69.7	25	10	78.2	13	28	52
50	5÷110	12	66.5	73.2	27	12	80.2	13	32	60
63	5÷110	16	74	80.7	32	12	89.7	17	40	70

Nota: para todas las otras dimensiones ver la versión standard

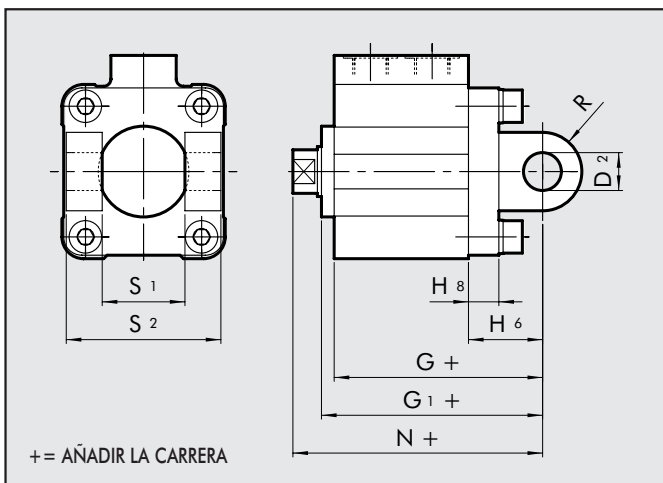

### DIMENSIONES VERSIÓN 221 (CHARNELA MACHO MOD. BA)

Ø carrera D<sub>2</sub> G G<sub>1</sub> H<sub>6</sub> H<sub>8</sub> N R S<sub>1</sub>

32	5÷70	10	59	62.8	22	10	70.3	11	26
40	5÷70	12	64.5	69.7	25	10	78.2	13	28
50	5÷110	12	66.5	73.2	27	12	80.2	13	32
63	5÷110	16	74	80.7	32	12	89.7	17	40

Nota: para todas las otras dimensiones ver la versión standard

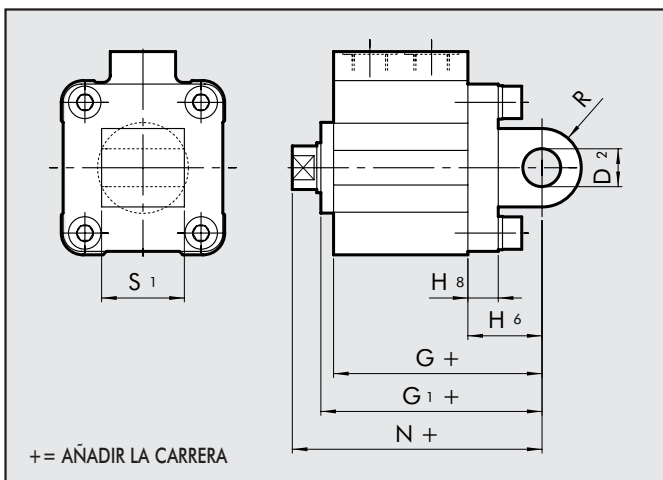



**DIMENSIONES: NIPLO MACHO PARA VÁSTAGO**

Códigos    Ø    Ø D    Ø d    B    C    CH    Peso [g]

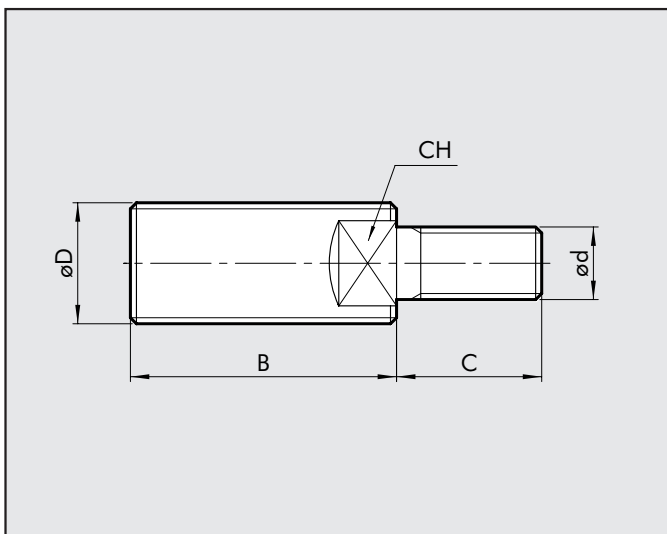

219001200	12	M6	M3	16	6	4	3
219001600	16	M8	M5	20	9	6	8
219001600	20	M8	M5	20	9	6	8
219002500	25	M10x1.25	M5	22	9	7	12
219003200	32	M10x1.25	M6	22	12	7	14
219004000	40	M12x1.25	M6	24	12	10	14
219005000	50	M16x1.5	M8	32	15	13	20
219005000	63	M16x1.5	M8	32	15	13	20
219008000	80	M20x1.5	M10	40	15	17	96
219010000	100	M20x1.5	M12	40	18	17	102

**RECAMBIOS PARA SSCY**

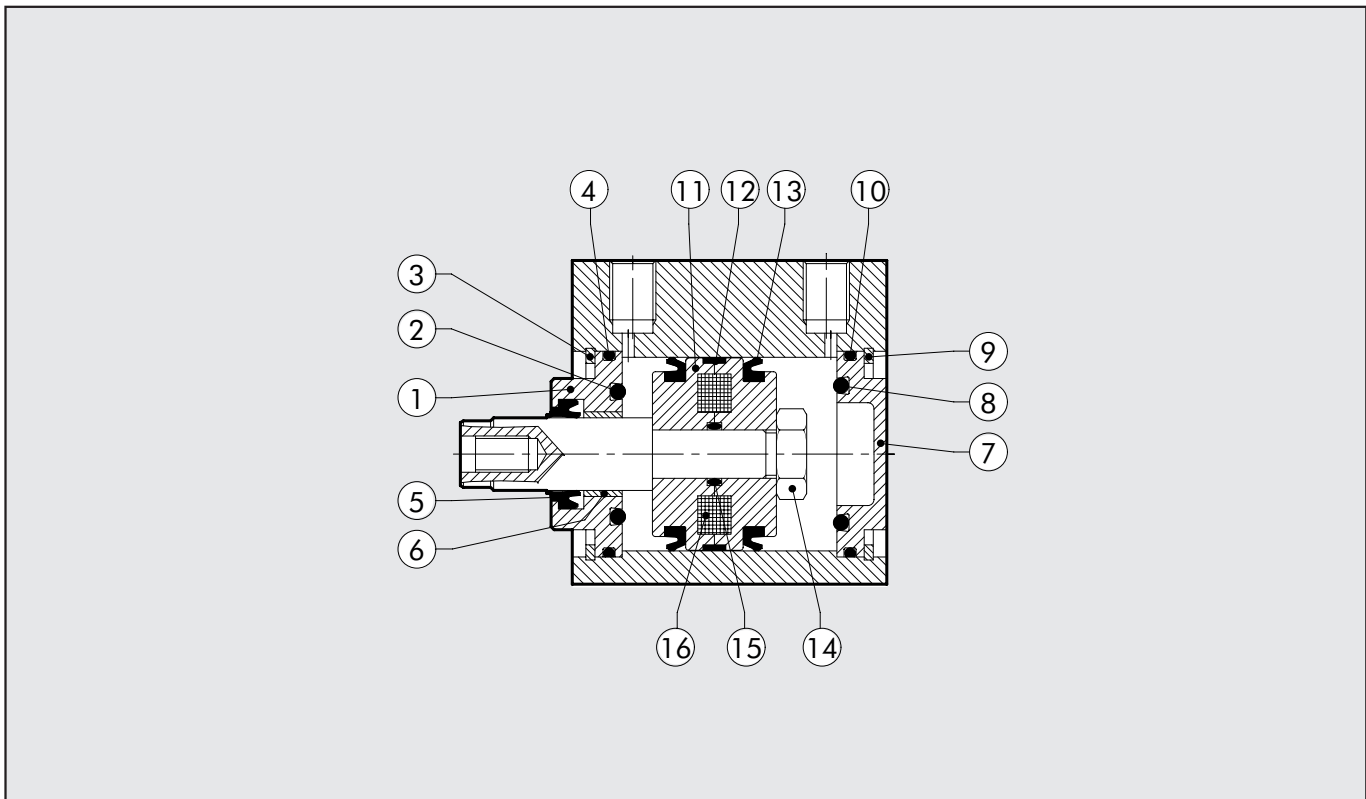

Tipología	Datos	Diámetro	Código
Kit casquillo ant. completo poliuretano	1-2-3-4-5-6	Ø 12÷100	009 ... 0010
Kit casquillo ant. completo NBR	1-2-3-4-5-6	Ø 12÷100	009 ... 0011
Kit casquillo post. completo	7-8-9-10	Ø 12÷100	009 ... 0015
Kit pistón completo poliuretano	11-12-13-14-15	Ø 12÷100	009 ... 0021
Kit pistón completo NBR	11-12-13-14-15	Ø 12÷100	009 ... 0023
Kit juntas completo poliuretano	2-4-5-8-10-13-15	Ø 12÷100	009 ... 0005
Kit juntas completo NBR	2-4-5-8-10-13-15	Ø 12÷100	009 ... 0006
Kit casquillo a. + p. pist. completo poliuretano	1-2-3-4-5-6-7-8-9-10-11-12-13-14-15	Ø 12÷100	009 ... 0031
Kit casquillo a. + p. completo NBR	1-2-3-4-5-6-7-8-9-10-11-12-13-14-15	Ø 12÷100	009 ... 0033
Imanes	16	Ø 12÷100	009 ... 0001

# ACCESORIOS: SENSORES MAGNÉTICOS

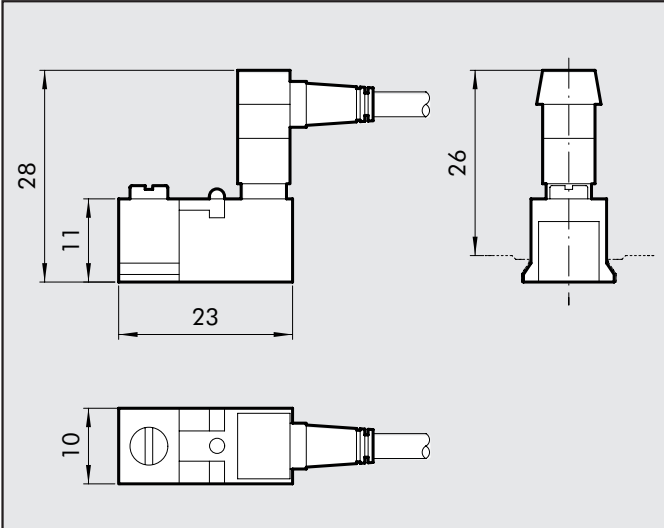
	Códigos	Versiones	Diámetro	Referencia
	W0950000252	Reed conector + abrazadera - CB	12÷100	SENSOR REED DCB 2C-425
	W0950000253	Hall PNP conector + abrazadera - CB	12÷100	SENSOR E Hall PNP DCB3-N225

## DATOS TÉCNICOS SENSORES DE PROXIMIDAD

Tipo		REED + VARISTORE + LED 2 hilos REED + VARISTORE + LED N.O. 110 cil. carrera corta	VERSION HALL PNP/NPN 3 hilos EFECTO HALL NO PNP/NPN 6-24 V DC
Contacto			
Tensión en AC/DC max.	V		
Corriente max. a 25°	mA	300	250
Potencia con carga inductiva	VA	8	-
Potencia con carga resistiva	Watt	15	6
Tiempo de inserción	m sec	0.5	0.8
Tiempo de desinserción	m sec	0.1	3
Punto de inserción	Gauss	110	15
Punto de desinserción	Gauss	60	8
Vida eléctrica	-	10 <sup>7</sup> impulsos	10 <sup>7</sup> impulsos
Resistencia de contacto		0.1	-
Longitud cable	m	2.5	2.5
Sección cable	mm <sup>2</sup>	0.35	0.35
Material cable		PVC blando	PVC blando

Circuito

### DC

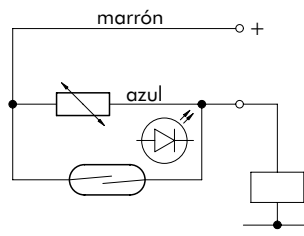

### AC

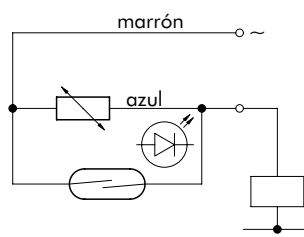

### Version NPN

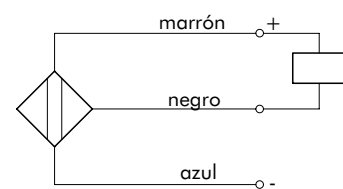

### Version PNP

