

DIMENSIONES PINZA P6-16

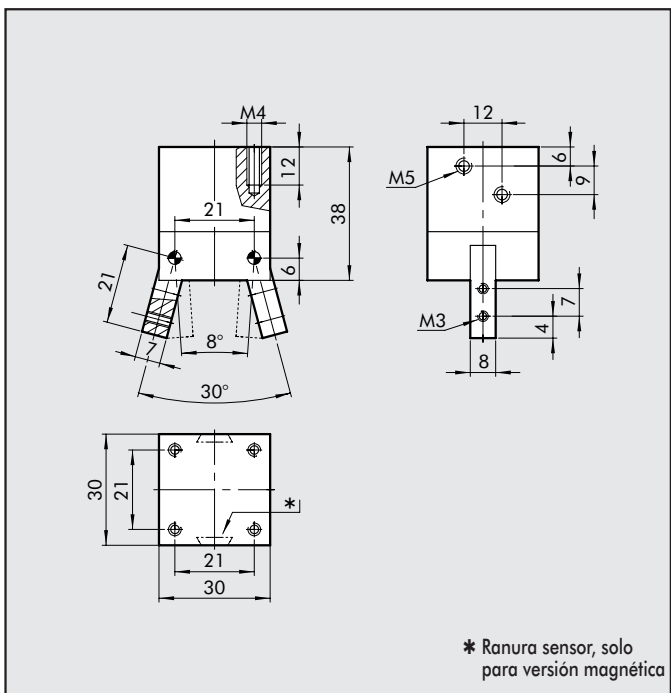

DIMENSIONES PINZA P6-20

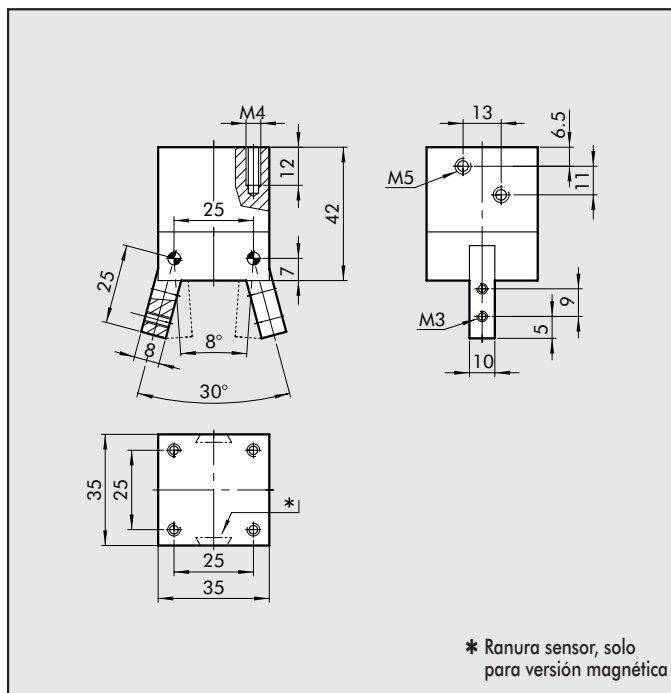

CÓDIGO DE PEDIDO

Código	Descripción
W1500160030	PINZA FUL. GR-016-LGH
W1510160030	PINZA FUL. GR-016-LGH-MAGN.

CÓDIGO DE PEDIDO

Código	Descripción
W1500200030	PINZA FUL. GR-020-LGH
W1510200030	PINZA FUL. GR-020-LGH-MAGN.

DIMENSIONES PINZA P6-32

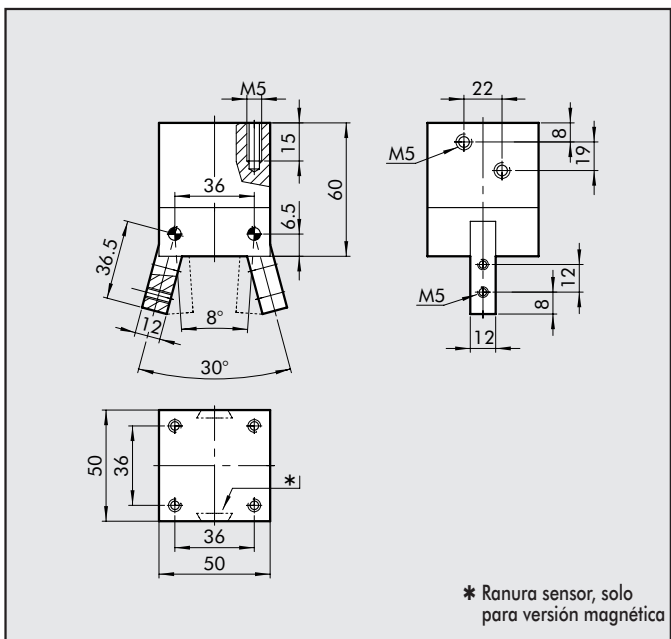

SENSOR MAGNÉTICO

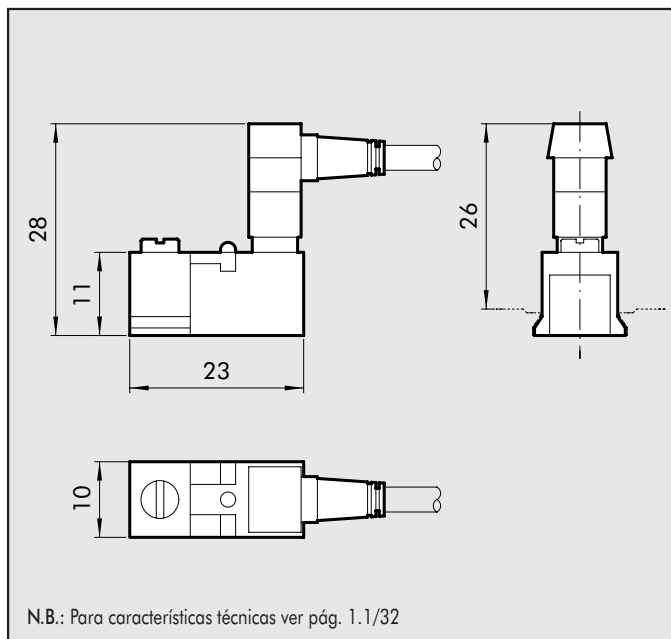

CÓDIGO DE PEDIDO

Código	Descripción
W1500320030	PINZA FUL. GR-032-LGH
W1510320030	PINZA FUL. GR-032-LGH-MAGN.

CÓDIGO DE PEDIDO

Código	Descripción	Sigla
W0950000252	Reed conector + soporte = CB	SENSOR REED DCB 2C-425
W0950000253	Hall PNP conector + soporte = CB	SENSOR E HALL PNP DCB3-N225