

[Vacuum pumps VTLP 40/G1, 50/G1, 65/G1 with oil loss lubrication]



They are vacuum pumps having a suction capacity of 40, 50, and 65 cum/h.

They are lubricated by depression with oil loss and lubrication is adjustable by means of two oilers placed in correspondence of the supporting bearings. The rotor is splined to its own shaft and is supported by bearings on both sides.

In this series, pump and motor are two independent units and the two shafts are coupled by means of an elastic joint. Cooling occurs by the surface. Heat is dispersed from the outer surface, suitably finned, by means of a radial fan placed between motor and pump.

A tank for the oil recovery is installed on the pump outlet, with the purpose to reduce noise and to eliminate smokes.

A safety valve is incorporated on this tank for the automatic drainage of the used oil between periodical changing. The lubricating oil is contained in a suitable transparent container fixed to the pump by means of its support and is controlled by a magnetic level switch.

In pumps with oil loss lubrication, lubricating oil, sucked into the pump by means of the drop oilers, is drained into the recovery tank together with the air without being put into circulation again. These pumps are recommended when in the sucked air there are water condensates, solvent vapours or any other thing that may contaminate the lubricating oil.

It is necessary to install a check valve and a suitable filter on the pump suction inlet to keep possible impurities sucked. This series of pumps can be supplied with three-phase electric motors only.

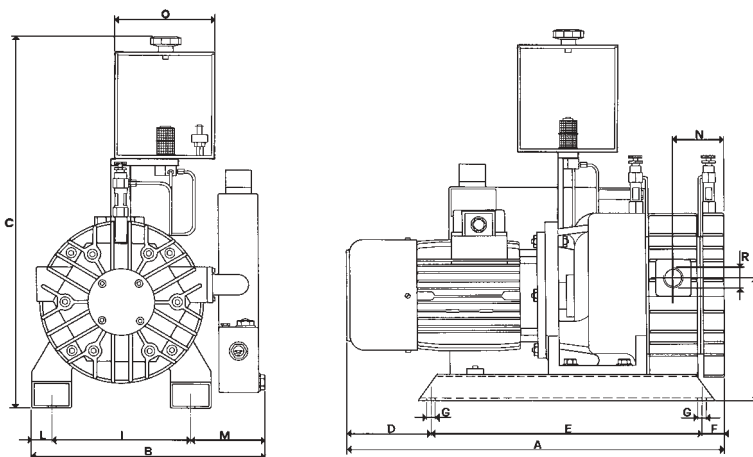

VTLP		40/G1	50/G1	65/G1
Capacity	cum/h	40	50	65
Final pressure	mbar abs.	50	50	50
Motor execution	Volt	230/400 ± 10%, 50Hz		
Motor power	Kw	1.1	1.5	2.2
Motor power	Hp	1.5	2	3
Rpm		1450	1450	1450
Max weight	Kg	52.5	55.1	72.6
A		520	560	610
B		365	365	380
C		525	525	525
D		60	115	150
E		415	415	415
F		45	30	45
G	ø	12.5	12.5	12.5
H		186	186	186
I		210	210	210
L		30	30	30
M		125	125	140
N		70	80	70
R	ø gas	1"	1"	1"1/4
O	ø	150	150	150