

[Vacuum pumps VTLP 10/F, 15/F, 20/F with oil loss lubrication]



These vacuum pumps have a suction capacity of 10, 15 and 20 cum/h.

They are lubricated by depression with oil loss and lubrication is adjustable by means of an oiler placed in correspondence of the suction inlet.

The rotor is splined to the motor shaft and is supported by independent bearings on both sides.

The pump is surface cooled.

Heat is dispersed from the outer surface, suitably finned, by means of a radial fan placed between motor and pump.

A tank for the oil recovery is installed on the pump outlet, this tank contains a separation filter that avoids forming of oil mists and reduces noise as well.

A safety valve is incorporated on this tank for the automatic drainage of the used oil between periodical changing. The lubricating oil is contained in a suitable transparent container fixed to the pump by means of its support and is controlled by a magnetic level switch.

In pumps with oil loss lubrication, lubricating oil, sucked into the pump by means of the drop oiler, is drained into the recovery tank together with the air without being put into circulation again. These pumps are recommended when in the sucked air there are water condensates, solvent vapours or any other thing that may contaminate the lubricating oil.

It is recommended to install a check valve and a suitable filter on the pump suction inlet.

This series of pumps can also be supplied with single-phase electric motors.

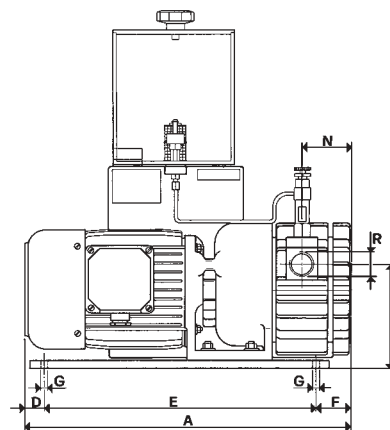
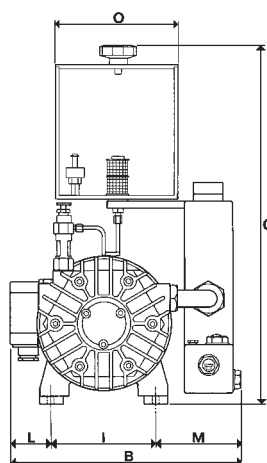

VTLP		10/F	15/F	20/F
Capacity	cum/h	10	15	20
Final pressure	mbar abs.	50	50	50
Motor execution	3 ~	230/400 ± 10%, 50 Hz		
Volt	1 ~	230 ± 10%, 50 Hz		
Motor power	3 ~	0.55	0.55	0.88
Kw	1 ~	0.55	0.55	0.66
Motor power	3 ~	0.75	0.75	1.20
Hp	1 ~	0.75	0.75	0.90
Rpm		1450	1450	1450
Max weight	3 ~	26.1	28.1	31.1
Kg	1 ~	26.6	28.6	31.6
A		385	405	425
B		285	285	285
C		440	440	440
D		25	25	25
E		340	340	340
F		20	40	60
G	Ø	8.5	8.5	8.5
H		133	133	133
I		130	130	130
L		55	55	55
M		100	100	100
N		53	63	73
R	Ø gas	1/2"	1/2"	1/2"
O	Ø	150	150	150