

[Vacuum pumps VTS 10/F, 15/F, 20/F, 25/F]

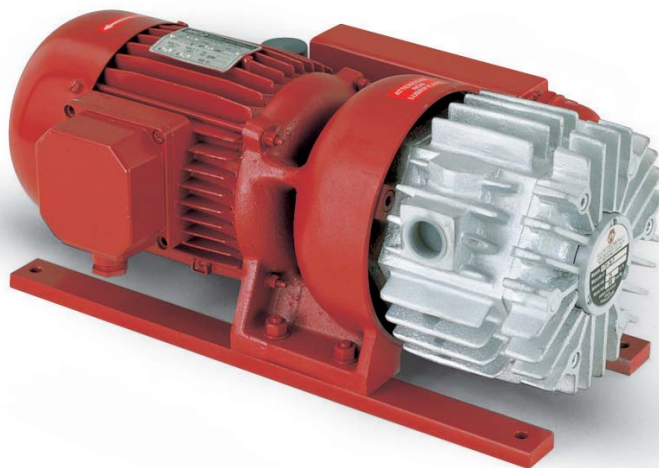

They are dry vacuum pumps having a suction capacity of 10, 15, 20 and 25 cum/h.

The particular shape of the working chamber and the special graphite which is used to manufacture the locking flanges and the vanes, allow these pumps to operate without any lubrication.

Pump rotor is splined to the motor shaft but it is independently supported on both sides by tight ball bearings.

Cooling occurs by surface.

Heat is dispersed from the outer surface suitably finned, by means of a radial fan placed between motor and pump.

A filter is installed on the pump outlet and it operates as a silencer.

It is recommended to install proper a filter on the pump suction inlet to keep possible sucked impurities.

These pumps may not be used when the sucked fluid contains vapours or water or oil condensates.

This series of pumps can also be supplied with single-phase electric motors.

The table shows all data and technical features of this series of pumps.

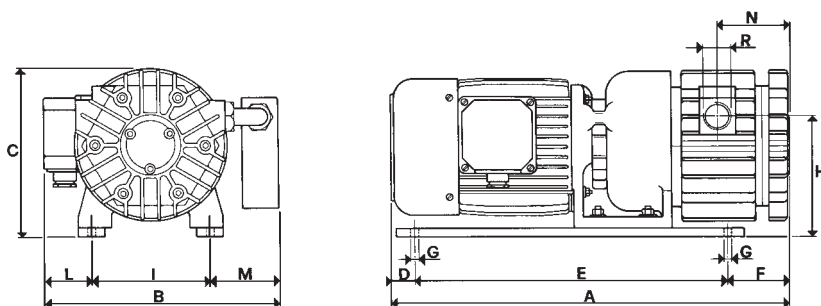

VTS		10/F	15/F	20/F	25/F
Capacity	cum/h	10	15	20	25
Final pressure	mbar abs.	80	80	80	80
Motor execution		230/400 ± 10%, 50 Hz			
Volt		230 ± 10%, 50 Hz			
Motor power	3 ~	0.55	0.55	0.88	0.88
Kw	1 ~	0.55	0.55	0.88	0.88
Motor power	3 ~	0.75	0.75	1.20	120
Hp	1 ~	0.75	0.75	1.20	1.20
Rpm		1450	1450	1450	1450
Max weight	3 ~	22.1	24.1	27.4	28.1
Kg	1 ~	22.5	24.5	27.9	28.6
A		388	408	428	428
B		260	260	260	260
C		187	187	187	187
D		24	24	24	24
E		340	340	340	385
F		24	44	64	19
G	Ø	8.5	8.5	8.5	8.5
H		133	133	133	133
I		130	130	130	130
L		55	55	55	55
M		75	75	75	75
N		53	63	73	73
R	Ø gas	1/2"	1/2"	1/2"	3/4"