

[Vacuum pumps VTS 2 and 4]

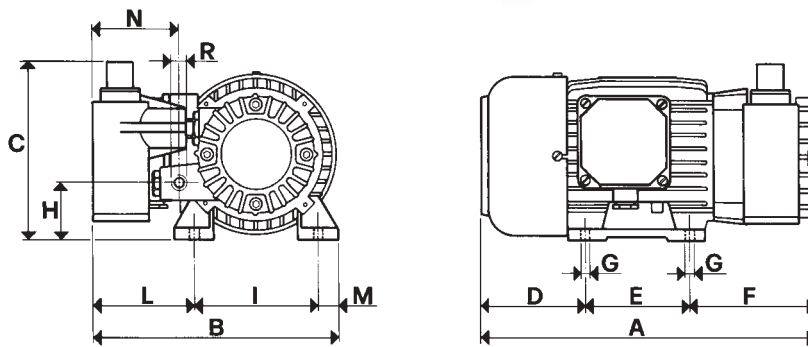

These small dry vacuum pumps have a suction capacity of 2 and 4 cum/h.

The particular shape of the working chamber and the special graphite which is used to manufacture the locking flanges and the vanes, allow these pumps to operate without any lubrication.

The rotor is overhanging splined to the motor shaft, making the pump smaller in dimensions. Motor and pump are cooled by the motor fan (surface cooling). A filter is installed on the pump outlet and it operates as a silencer.

It is recommended to install a proper filter on the pump suction inlet to keep possible sucked impurities.

These pumps may not be used when the sucked fluid contains vapours or water or oil condensates. Pumps VTS 2 and 4 can also be supplied with single-phase electric motor.

The table shows all data and technical features of this series of pumps.

VTS		2	4
Capacity	cum/h	2	4
Final pressure	mbar abs.	150	150
Motor execution	3 ~	230/400 ± 10%, 50 Hz	
Volt	1 ~	230 ± 10%, 50 Hz	
Motor power	3 ~	0.13	0.15
Kw	1 ~	0.13	0.15
Motor power	3 ~	0.18	0.20
Hp	1 ~	0.18	0.20
Rpm		2900	2900
Max weight	3 ~	5.3	6.8
Kg	1 ~	5.5	7.0
A		217	251
B		180	186
C		121	131
D		66	78
E		71	81
F		80	92
G	Ø	6.5	6.5
H		35	45
I		90	100
L		79	73
M		11	13
N		65	65
R	Ø gas	1/4"	1/4"