

# **AS-INTERFACE USER MANUAL**

---







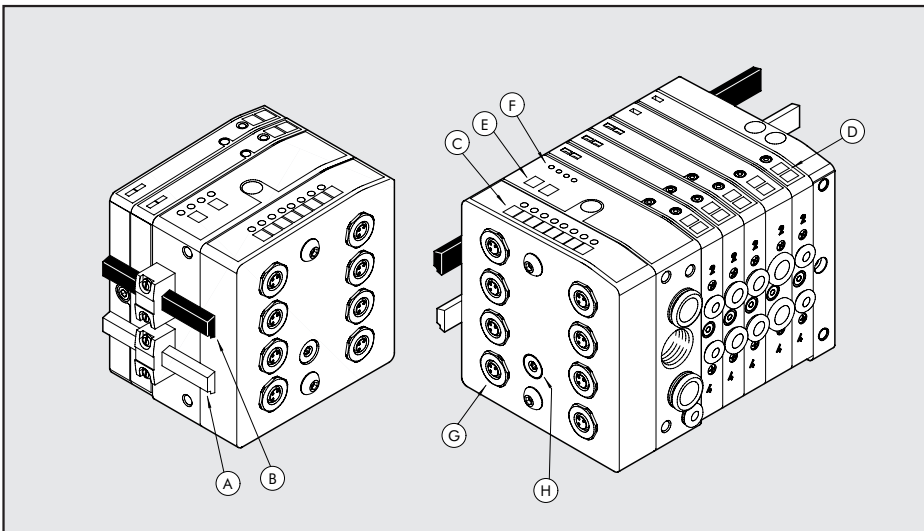





Heavy-Duty Multimach – AS-Interface valves are used to connect HDM islands to an AS-I network. In compliance with V2.1 AS-Interface specifications, they offer diagnostic functions and are available according to the model with standard address or A/B extended address. The standard address provides 4 outputs and 4 inputs for each slave module, with a maximum of 31 modules for each master, giving a total of 124 outputs and 124 inputs. The extended A/B address provides 3 outputs and 4 inputs for each slave module, with a maximum of 62 modules for each master, giving a total of 186 outputs and 248 inputs. The inputs available with M8 and M12 connectors are compatible with PNP type 2 or 3 wire sensors and are protected from overloads and short-circuiting. The modules are available in models AS/AO/AE with the connection of the AS-I yellow cable only, which allows the transmission of data and power supply through one cable only of the modules and inputs/outputs. Models AZ and AE must be fed with auxiliary power supply via the black cable. This allows a separate power supply for inputs and outputs, which can be deactivated. For full details of the design and address of the AS-Interface, refer to the user manual of the Master being used.

## 1. CONNECTION AND SIGNAL ELEMENTS

- Ⓐ Connection to the AS-Interface bus via the connector provided.
- Ⓑ Connection for auxiliary valve and sensor power supply (versions AZ and AE only), with which it is possible to deactivate the valves and sensors, following an emergency stop, maintaining the slave active and in communication with the Master.
- Ⓒ Input identification tags/indicator LEDs
- Ⓓ Output identification plates
- Ⓔ AS-I address identification plates
- Ⓕ Diagnostics LED
- Ⓖ Input connections
- Ⓗ Address selection key placed under the protection plug



The diagnostics of an HDM AS-I module is defined by the status of the interface LEDs:

Green AS-i LED	Red Fault LED	Meaning
ON 	OFF 	The modules work properly
OFF 	OFF 	No AS-I power supply
OFF 	ON 	The module does not communicate
FLASHING 	ON 	Module with zero address
Alternate FLASHING 	Alternate FLASHING 	Peripheral failure: - no auxiliary power supply - coil short-circuit or overload - coil interrupted or absent but controlled by the Master - input voltage > 37V
OFF 	FLASHING 	Internal failure



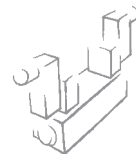

## 2. INSTALLATION

It is advisable to use MW female connectors to connect the valve modules.

**This is the only way to ensure IP65 protection.**

Proceed as follows:

- Insert the AS-I cable in the shaped support. Press gently to join the two parts until the two side clips are perfectly engaged so as to ensure correct perforation of the insulation by the contact elements.
- Insert the shaped gasket to ensure IP65 protection.
- Connect the connector to the valve module called BUS and secure it with the screws provided.
- The valve modules of type AZ/AE require a 24VDC  $\pm 10\%$  auxiliary power supply. Repeat the above operations for assembling the connector and cable.
- Connect the connector to the valve module marked 24VDC and secure it in position with the screws provided.

### Bus connection cable (yellow)

- 1 AS-i + (brown)
- 2 AS-i - (blue)

### Auxiliary power supply cable (black)

- 1 +24 VDC (brown)
- 2 0 V (blue)

### CAUTION

Power off the system before plugging in or unplugging the connectors (risk of functional damage).

Connect one of the fixing holes of the unused island for earthing using an appropriate conductor. **The absence of earthing may cause malfunctions or irreversible damage in event of electrostatic discharges.**

Use fully assembled valve units only.

For connection to the AS-I bus, only use power supplies corresponding to AS-I specifications.

For auxiliary power supply, only use power supplies to IEC 742/ EN60742/VDE0551 with minimum 4kV (PELV) insulation resistance.

Unconnected cable ends must be suitably insulated so as to prevent the formation of dispersion currents and guarantee an IP65 index of protection.

### EXAMPLE OF VALVE UNIT CONNECTION

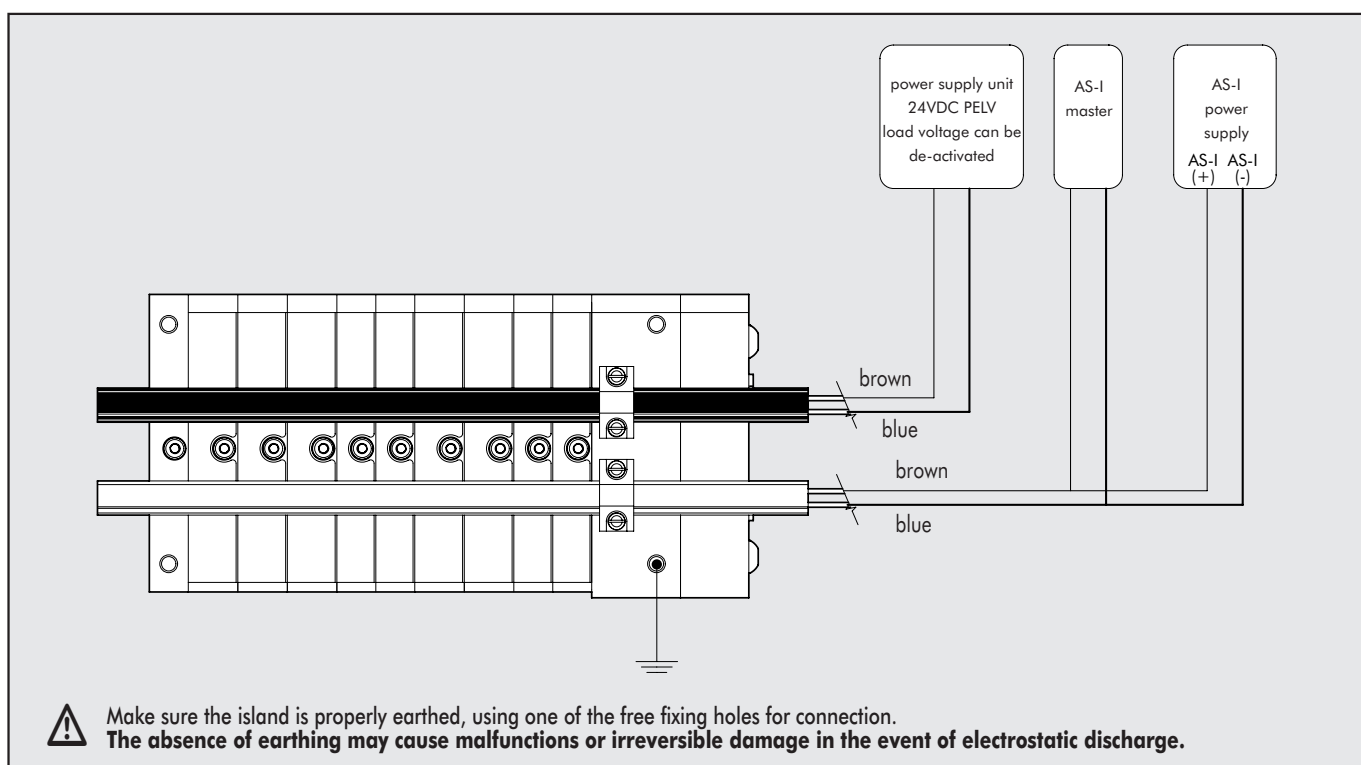

### 3. ADDRESS

#### 3.1 Assigning the AS-I slave address

Before connecting a slave to the bus system, it is advisable to assign it a free address with the AS-Interface address unit. There are two types of configuration unit, ① and ②, both to ensure addressing, parameterisation, testing and diagnosis.



Both can be used to address the modules by connecting cable MW cod. 0226950150 to the M12 connector. It is also possible to provide address from the Master, if allowed. For the procedure, refer to the instructions of the Master being used.

#### CAUTION

The HDM AS-I modules comply with the V2.1 specification, AS-Interface profile (I/O code, ID code, ID1, ID2) S7. It is thus necessary to use address units that are compatible with this version. Units compatible with version V1 only may, when used with V2.1 components, generate ID1 address or overwrite errors.

#### Procedure:

Connect the address unit to the BUS connector of the island via the M12-AS-I interface cable. Select the desired address on the unit and send it to the island.

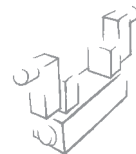

### 3.2 Assigning data bits to the inputs/outputs in the single node

		I/O 8 <sub>H</sub> code				I/O 7 <sub>H</sub> code			
		D0	D1	D2	D3	D0	D1	D2	D3
Data bits		S	S	S	S	I/O	I/O	I/O	I/O
Outputs		O1	O2	O3	O4	O1	O2	O3	O4
						I1	I2	I3	I4

### 3.3 Solenoid output addresses for each node

Example of units with 2 bistable valves*				Example of units with 4 monostable valves*			
O1		O3		O1	O2	O3	O4
O2		O4					

\*Mixed combinations are possible. Address mapping depends on the configuration of the Master.

### 3.4 Assigning data bits to the inputs/outputs in the double node ( AS 8 - AZ 8 – AE 8 )

Inside valve modules type AS 8 / AZ 8 / AE 8, there are two AS-Interface Slaves. In the bus, each module acts as 2 separate slaves, with 4 outputs and, if present, 4 inputs each.

1° node		I/O 8 <sub>H</sub> code				I/O 7 <sub>H</sub> code			
		D0	D1	D2	D3	D0	D1	D2	D3
Data bits		S	S	S	S	I/O	I/O	I/O	I/O
Outputs		O1	O2	O3	O4	O1	O2	O3	O4
						I1	I2	I3	I4

2° node		I/O 8 <sub>H</sub> code				I/O 7 <sub>H</sub> code			
		D0	D1	D2	D3	D0	D1	D2	D3
Data bits		S	S	S	S	I/O	I/O	I/O	I/O
Outputs		O5	O6	O7	O8	O5	O6	O7	O8
						I5	I6	I7	I8

### 3.5 Solenoid output addresses for double node

Example of units with 2 bistable valves*				Example of units with 8 monostable valves*							
O1	O3	O5	O7	O1	O2	O3	O4	O5	O6	O7	O8
O2	O4	O6	O8								

\*Mixed combinations are possible. Address mapping depends on the configuration of the Master.

#### 4. TECHNICAL DATA

For the technical features, refer to the description provided for the compressed air system

Type	AS- 4	AZ- 4	AS - 8	AZ - 8
<b>Description</b>	4 output	4 output	8 out (double node)	8 out (double node)
<b>As-i version</b>	V2.1	V2.1	V2.1	V2.1
<b>Profile</b>	S.8.F.F.E.	S.8.F.F.E.	S.8.F.F.E.	S.8.F.F.E.
<b>I/O code</b>	8 <sub>H</sub>	8 <sub>H</sub>	8 <sub>H</sub>	8 <sub>H</sub>
<b>ID code</b>	F <sub>H</sub>	F <sub>H</sub>	F <sub>H</sub>	F <sub>H</sub>
<b>ID1</b>	F <sub>H</sub>	F <sub>H</sub>	F <sub>H</sub>	F <sub>H</sub>
<b>ID2 code</b>	E <sub>H</sub>	E <sub>H</sub>	E <sub>H</sub>	E <sub>H</sub>
<b>Factory settings: address</b>	#0	#0	#1 - #2	#1 - #2
<b>AS-interface power supply</b>	26.5 31.6 VDC To AS-i spec.	26.5 31.6 VDC To AS-i spec.	26.5 31.6 VDC To AS-i spec.	26.5 31.6 VDC To AS-i spec.
<b>Protection</b>	From discharges and polarity inversion	From discharges and polarity inversion	From discharges and polarity inversion	From discharges and polarity inversion
<b>Max current absorption (all valves ON)</b>	<120 mA Outputs protected from overloads and short-circuits	<25 mA	<250 mA Outputs protected from overloads and short-circuits	<50 mA
<b>Auxiliary power supply</b>	/	24 VDC ± 10%	/	24 VDC ± 10%
<b>Protection</b>	/	From discharges and polarity inversion	/	From discharges and polarity inversion
<b>Max current absorption (all valves ON)</b>	/	<100 mA Outputs protected from overloads and short-circuits	/	<200 mA Outputs protected from overloads and short-circuits
<b>Address</b>	Via address units and dedicated connecting cable. From Master.	Via address units and dedicated connecting cable. From Master.	Via address units and dedicated connecting cable.	Via address units and dedicated connecting cable.
<b>Max number of addresses</b>	31			
<b>Peripheral fault diagnostics</b>	Indication via LEDs			
<b>Faults detected</b>	Shortcircuit or output overload Coil cut out or absent (if controlled) No auxiliary power supply Input voltage > 37V			
<b>Module status in the event of a peripheral fault</b>	AS-i communication active The "Peripheral Fault" bit is active and accessible from the master station			
<b>Data bit value</b>	0 = Not active 1 = active			
<b>Output state in the absence of communication</b>	Inactive			
<b>Electric TRA</b>	< 1.5 ms			
<b>Electric TRR</b>	< 0.8 ms			

#### NOTES

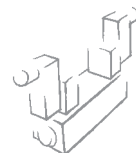

Type	AO- 4	AE- 4	AE - 8
<b>Description</b>	4 output/ 4 input	4 output/ 4 input	8 out/ 8 input (double node)
<b>AS-i version</b>	V2.1	V2.1	V2.1
<b>Profile</b>	S.7.F.F.E.	S.7.F.F.E.	S.7.F.F.E.
<b>I/O code</b>	7 <sub>H</sub>	7 <sub>H</sub>	7 <sub>H</sub>
<b>ID code</b>	F <sub>H</sub>	F <sub>H</sub>	F <sub>H</sub>
<b>ID1</b>	F <sub>H</sub>	F <sub>H</sub>	F <sub>H</sub>
<b>ID2 code</b>	E <sub>H</sub>	E <sub>H</sub>	E <sub>H</sub>
<b>Factory settings: address</b>	#0	#0	#1 - #2
<b>AS-interface power supply</b>	26.5 31.6 VDC To AS-i spec.	26.5 31.6 VDC To AS-i spec.	26.5 31.6 VDC To AS-i spec.
<b>Protection</b>	From discharges and polarity inversion	From discharges and polarity inversion	From discharges and polarity inversion
<b>Max current absorption (all valves ON) With the exclusion of the sensor power supply</b>	<120 mA Outputs protected from overloads and short-circuits	<25 mA	<50 mA
<b>Auxiliary power supply</b>	/	24 VDC ± 10%	24 VDC ± 10%
<b>Protection</b>	/	From discharges and polarity inversion	From discharges and polarity inversion
<b>Max current absorption (all valves ON) with the exclusion of the sensor power supply</b>	/	<100 mA Outputs protected from overloads and short-circuits	<200 mA Outputs protected from overloads and short-circuits
<b>Address</b>	Via address units and dedicated connecting cable. From Master.	Via address units and dedicated connecting cable. From Master.	Via address units and dedicated connecting cable.
<b>Max no. of addresses</b>	31		
<b>Peripheral fault diagnostics</b>	Indication via LEDs		
<b>Faults detected</b>	Shortcircuit or output overload Coil cut out or absent (if controlled) No auxiliary power supply Input voltage > 37V		
<b>Module status in the event of a peripheral fault</b>	AS-i communication active The "Peripheral Fault" bit is active and accessible from the master station		
<b>Data bit value</b>	0 = Not active 1 = active		
<b>Output state in the absence of communication</b>	Inactive		
<b>Electric TRA</b>	< 1.5 ms		
<b>Electric TRR</b>	< 0.8 ms		

## NOTES

## 5. FEATURES OF THE MODULES WITH EXTENDED A/B ADDRESS

### 5.1 Assigning the AS-I Slave address

The address of the valve modules is only allowed with the address units according to specification 3.0. Other units may allow non-univocal access; if necessary, overwrite the ID1 codes.

Before connecting a Slave to the bus system, it is advisable to assign it a free address, with the AS-interface address unit.

**Double-node versions : AS-6, AZ-6, AE-6.**

If the same address has been assigned by mistake to both slaves, univocal access is no longer possible. In this case, disconnect slave 1 from the AS-I bus, press the address selection key and assign a new address to slave 2.

### 5.2 Assigning data bits to the inputs/outputs

#### I/O 7<sub>H</sub> code

	D0	D1	D2	D3
Data bit	I/O	I/O	I/O	I/O
Outputs	O1	O2	O3	O4
Inputs*	I1	I2	I3	I4

• for AO-3, AE-3, AE-6 type only

#### 5.2.1 Solenoid output addresses

Units with 2 bistable valves		Units with 4 monostable valves			
O1	O3	O1	O2	O3	O4
O2	O4				

\*Mixed combinations are possible. Address mapping depends on the configuration of the Master.

### 5.3 Assigning data bits to the inputs/outputs in the double node (AS 6 - AZ 6 - AE 6)

Inside valve modules AS 6 / AZ 6 / AE 6, there are two AS-Interface Slaves.

In the bus, each module acts as 2 separate slaves, with 3 outputs and, if present, 4 inputs each.

#### I/O 7<sub>H</sub> code

	D0	D1	D2	D3
Data bit	I/O	I/O	I/O	I/O
Outputs	O1	O2	O3	O4
Inputs*	I1	I2	I3	I4

• for AO-3, AE-3, AE-6 type only

#### I/O 7<sub>H</sub> code

	D0	D1	D2	D3
Data bit	I/O	I/O	I/O	I/O
Outputs	O5	O6	O7	O4
Inputs*	I5	I6	I7	I8

• for AO-3, AE-3, AE-6 type only

#### 5.3.1 Solenoid output addresses

Units with 4 bistable valves				Units with 8 monostable valves							
O1	O3	O5	O7	O1	O2	O3	O4	O5	O6	O7	O8
O2	O4	O6	O8								

\*Mixed combinations are possible. Address mapping depends on the configuration of the Master.

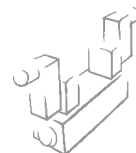

## 5.4 TECHNICAL DATA

Type	AS- 3	AZ- 3	AS - 6	AZ - 6
<b>Description</b>	3 output	3 output	6 out (double node)	6 out (double node)
<b>As-i version</b>	V3.0	V3.0	V3.0	V3.0
<b>Profile</b>	S.7.A.7.7.	S.7.A.7.7.	S.7.A.7.7.	S.7.A.7.7.
<b>I/O code</b>	7 <sub>H</sub>	7 <sub>H</sub>	7 <sub>H</sub>	7 <sub>H</sub>
<b>ID code</b>	A <sub>H</sub>	A <sub>H</sub>	A <sub>H</sub>	A <sub>H</sub>
<b>ID code1 (A-Slave)</b>	7 <sub>H</sub>	7 <sub>H</sub>	7 <sub>H</sub>	7 <sub>H</sub>
<b>ID code1 (B-Slave)</b>			F <sub>H</sub>	F <sub>H</sub>
<b>ID2 code</b>	7 <sub>H</sub>	7 <sub>H</sub>	7 <sub>H</sub>	7 <sub>H</sub>
<b>Factory settings: address</b>	#0 A-Slave	#0 A-Slave	Slave 1 = #1-A ID1=7 <sub>H</sub> Slave 2 = #1-B ID1=F <sub>H</sub>	Slave 1 = #1-A ID1=7 <sub>H</sub> Slave 2 = #1-B ID1=F <sub>H</sub>
<b>AS-interface power supply</b>	26.5 31.6 VDC To AS-i spec.	26.5 31.6 VDC To AS-i spec.	26.5 31.6 VDC To AS-i spec.	26.5 31.6 VDC To AS-i spec.
<b>Protection</b>	From discharges and polarity inversion	From discharges and polarity inversion	From discharges and polarity inversion	From discharges and polarity inversion
<b>Max current absorption (all valves ON)</b>	<120 mA Outputs protected from overloads and short-circuits	<25 mA	<250 mA Outputs protected from overloads and short-circuits	<50mA
<b>Auxiliary power supply</b>	/	24 VDC ±10%	/	24 VDC ±10%
<b>Protection</b>	/	From discharges and polarity inversion	/	From discharges and polarity inversion
<b>Max current absorption (all valves ON)</b>	/	<100 mA Outputs protected from overloads and short-circuits	/	<200 mA Outputs protected from overloads and short-circuits
<b>Address</b>	Via address units and dedicated connecting cable.	Via address units and dedicated connecting cable.	Via address units and dedicated connecting cable.	Via address units and dedicated connecting cable.
<b>Max no. of addresses</b>	62			
<b>Peripheral fault diagnostics</b>	Indication via LEDs			
<b>Faults detected</b>	Shortcircuit or output overload Coil cut out or absent (if controlled) No auxiliary power supply			
<b>Module status in the event of a peripheral fault</b>	Input voltage > 37V AS-i communication active The "Peripheral Fault" bit is active and accessible from the master station			
<b>Data bit value</b>	0 = Not active 1 = active			
<b>Output state in the absence of communication</b>	Inactive			
<b>Electric TRA</b>	< 1.5 ms			
<b>Electric TRR</b>	< 0.8 ms			

## NOTES



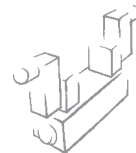

## CONNECTING THE SENSORS (PNP INPUTS)

Use connectors M8X1 or M12X1 according to the model to connect the sensors. Lock the ring nut right in position to prevent it from disconnecting accidentally. Plug any connections not in use. This is to ensure the degree of protection IP65.

<b>Sensor type</b>	PNP 2 and 3 wires			
<b>Input conformity</b>	to IEC 61131-2 Type 2			
<b>Supply voltage</b>	24 VDC $\pm$ 10%			
<b>Max sensor supply current</b>	90 mA			
<b>State 1 guaranteed</b>	U > 14V and I > 2 mA			
<b>State 0 guaranteed</b>	U < 8 V and I < 1 mA			
<b>Protection</b>	against overloads and shortcircuits			
<b>Diagnostics</b>	Overload indicator orange LED Shortcircuit indicator red LED			
	The "Peripheral Fault" bit is active and accessible from the master station			
<b>M8 X 1 connector pin array</b>	1 : +24 V 3 : 0 V 4 : input			
<b>M12 X 1 connector pin array</b>	X1	X2	X3	X4
	1 : +24 V	1 : +24 V	1 : +24 V	1 : +24 V
	2 : input 2	2 : not connected	2 : input 4	2 : not connected
	3 : 0 V	3 : 0 V	3 : 0 V	3 : 0 V
	4 : input 1	4 : input 2	4 : input 3	4 : input 4

## NOTES