

Vacuum gauges

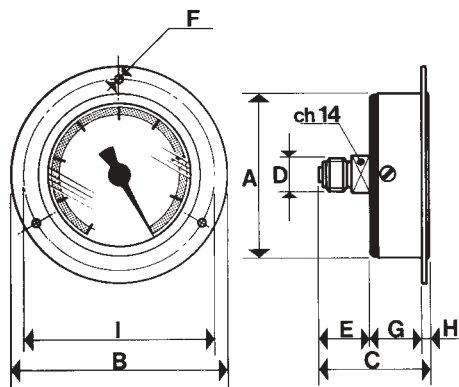

09 01 10
09 01 16
09 02 10
09 03 10
09 03 15

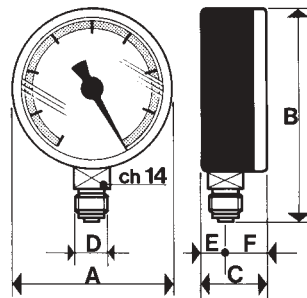

09 05 10
09 05 16

Art.	A Ø	B	B Ø	C	D Ø	E	F	F Ø	G	H	I Ø
09 01 10	63	--	85	49	1/4"	21	--	3.5	24	4	75
09 01 16	63	--	85	59	1/4"	22	--	3.5	33	4	75
09 02 10	100	--	132	52	1/4"	21	--	4.5	26	5	116
09 03 10	63	--	--	49	1/4"	21	--	--	25	3	--
09 03 15	40	--	--	41	1/8"	16	--	--	23	2	--
09 05 10	63	87	--	27	1/4"	9	18	--	--	--	--
09 05 16	68	87	--	37	1/4"	11	26	--	--	--	--

The measurement method of our vacuum gauges is a Bourdon spring.

It is made using section tubes in special copper alloy, one extremity is welded to the threaded pin of the vacuum gauge, thus forming a single body with it, the other closed extremity is free.

By the increasing of the vacuum inside, it tends to warp from its original position (Bourdon effect). The movement of the free spring extremity gives the measure of the vacuum.

In order to allow an easier reading, this movement is amplified by means of a connection lever and transmitted to the pointer.

All these parts are enclosed in a strong metal case, containing the dial and the pointer that can be seen through a glass.

Double scale : from 0 to -1000 mbar
from 0 to -100 KPa

Accuracy : 2,5% of scales Ø 40 and Ø 63;
1,6% of scales Ø 63 in glycerine filled types;
1% of scale Ø 100.

Connection : coaxial or radial

Temperature range : from -10°C to +50°C

Arts. 09 ..16 are glycerine filled vacuum gauges. The above described vacuum gauges are manufactured in compliance with all the safety rules and measurement units in force.