

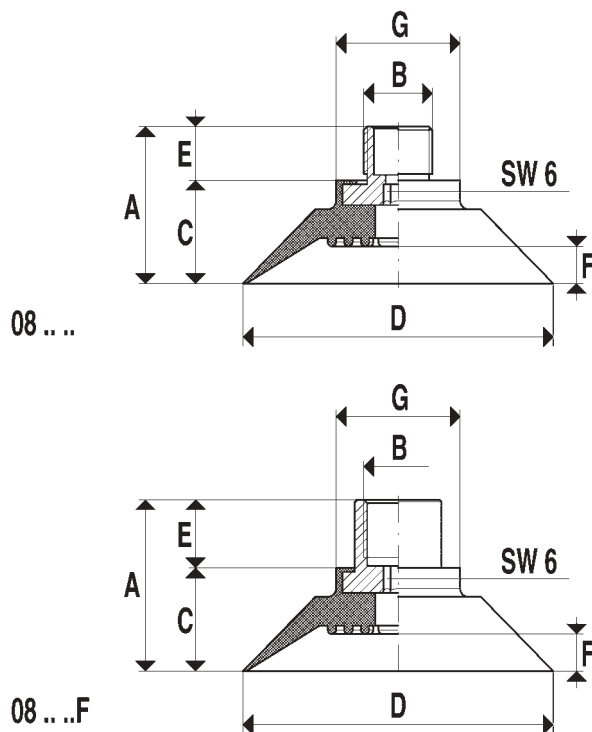

[Special cups with support]



Designed and manufactured for the purpose of handling stamped or drawn plates, these cups are used predominately in the motor field.

They have a ground lip, which permits an immediate grip of the load to be lifted as soon as contact is made and assures a perfect vacuum seal.

These cups are produced in a special compound called BENZ, able to withstand chlorine usually contained in the oils for the stamping and drawing of plates.

The support is zinc-plated steel and is vulcanized on the cup.

They are available in the three series of compounds.

Art.	Force Kg.	A	B Ø	C	D Ø	E	F	G Ø
08 50 40	4.90	29.0	3/8"	16.0	50	13.0	6.5	31
08 75 40	11.04	38.0	3/8"	25.0	75	13.0	9.0	31
08 100 40	19.62	39.0	3/8"	26.0	100	13.0	9.0	32
08 100 50	19.62	43.5	3/8"	30.5	100	13.0	15.0	32
08 50 40F	4.90	32.5	3/8"	16.0	50	16.5	6.5	31
08 75 40F	11.04	41.5	3/8"	25.0	75	16.5	9.0	31
08 100 40F	19.62	42.5	3/8"	26.0	100	16.5	9.0	32
08 100 50F	19.62	47.0	3/8"	30.5	100	16.5	15.0	32